

Improvement of Power Management System in Electro-Solar Vehicle

Hemza SAIDI¹, Abdelhamid MUDOUN²

^{1,3}Electrical Engineering Department, Mohamed Boudiaf University of Science and Technology, Oran, Algeria, e-mail: hamzaing2008@yahoo.fr, ah_midoun@hotmail.com

ABSTRACT

Electric vehicles are ultimately a real answer to current problems related to environmental pollution and noise in cities. In line with current public issues, the electric vehicle is quiet. In addition, it is considered as environmentally friendly since it does not emit CO₂. This paper tries to answer the question 'does solar energy able to compensate fossil energy in the means of land transport? ', and highlight a new approach to improve energy management in a solar car. The global objectives of the energy management system are to guarantee the general power balance, and to get the maximal amount of braking energy. Electric vehicle is a complex assembly that includes various parts like mechanical, electrical, control, pneumatic, electrochemical and management etc... A fully autonomous vehicle in real dimensions was built to implement the new strategy and management control using Matlab/Simulink and electronics compounds.

A prototype electric vehicle was built having reached speed of 100km/h and an autonomy range of 60km with a minimum number of PV module and on-board batteries

Keywords-Solar Car, battery management systems, electric vehicle, hybrid power systems, MPPT, traction power supplies.

1. INTRODUCTION

Algeria is among the firsts countries producing oil and gas. And that doesn't prevent the government to implement a policy for the development of Renewable Energies (RE) and adopt gradually mix energy. The objective is to attain 40% of its electricity production from renewable energy source, by 2030, according to its international commitments, to protect the planet.

In this context, efforts to improve air quality in heavily populated urban communities- by reducing vehicular emissions – have rekindled interest in the development of electric vehicle technology. To our knowledge until now no electric vehicle is used in Algeria. Fabricate a solar vehicle presents a tremendous engineering challenge requiring the design and the integration of various aspects of the vehicle as the electric engine, suspensions, the body, the drive train, the fuel system, the electrical systems, and the climate control-chain. All these aspects are time-consuming and costly. The access to energy, the environmental and climate problems, and the need to solve

the mobility problems in the cities are all fields in which electric, hybrid and fuel cells vehicles offer a large attractive prototype and necessary solutions.

This paper addresses the design considerations involved in the electric vehicle conversion which includes: removal of internal combustion engine and related parts, choice of electric vehicle components, installation of electric vehicle accessory system and design of battery chargers with specific applications to electric vehicles. As the battery is the most important part in an electric vehicle therefore the energy density and the power density are the first battery's parameters to be considered. The power density of proton exchange membrane fuel cells (PEMFC) is significantly higher and it is able to work at ambient temperature. Most of the car companies develop big efforts to integrate the PEM fuel cells in a small part of the car body.

Many solutions regarding friendly alternate vehicles are raised, and the questions regarding practical development of these vehicles owing to their high initial technology development cost. The specialty of these vehicles is they are zero emission vehicles. (Jaegul Lee et al) propose dynamic state, empirical model of energy and power as the state variables derived from electrical behaviour of a lead acid battery system [5].

The empirical model describes the relationship between the total, usable and loss of power and energy under dynamic load conditions. Juan W. Dixon, Micah Ortúzar and Eduardo Wiechmann did work on regenerative braking for an electric vehicle using ultra capacitors [6/7]. (Vidyadhar Gulhane, et al), conclude that the main problems are the poor battery performance, under developed control circuit and inadequate capacity of electric motor to match with the road situation [7].

For the lead-acid batteries used in this work, the energy density is too low to meet the energy requirements when vehicles accelerate, decelerate and brake frequently.

Section II of this paper presents the design environment of the vehicle. **Section III** is devoted to the design of the system. **Sections IV** and **V** present the control and energy management strategy used in the Electro-solar vehicle. Finally, **Section VI** presents a set of simulation results and comments.

Note: During manufacturing, we were constrained to change many parts in the study according to the available

means, and that leads to limit the performance. We have to indicate the lack of tools which are necessary to the achievement of our project we need.

2. DESIGN ENVIRONMENT

The urban drive cycle was used as input to represent the road load. Signals of power were passed through the modules. In a mechanical module, the power was the production of torque and rotation speed fig 1. In the electrical module, the power was the production of voltage and current. The reverse simulation showed if the power was transmitted through vehicle module, traction motor module, energy management and control module and battery module. The forward simulation showed if the power was transmitted through the opposite direction.

The road slope torque T is defined by:

$$T_w = \frac{P}{2} \cdot c_w \cdot A \cdot v^2 \quad (1)$$

$$T_R = k_R \cdot m \cdot g \cdot \cos \alpha \quad (2)$$

$$T_A = k_m \cdot m \cdot a \quad (3)$$

$$T_G = m \cdot g \cdot \sin \alpha \quad (4)$$

$$T = T_w + T_R + T_A + T_G \quad (5)$$

Where; T_w is aerodynamic torque, T_R : rolling torque, T_A acceleration torque and T_G gradient torque.

Torque evaluation Evaluation of the power flow occurring into a vehicle is in strong relation with his mass and a total couple will be expressed as:

$$C_t = T_A + T_{permanent} \quad (6)$$

Where; m is a vehicle mass, C_t total torque, T_A

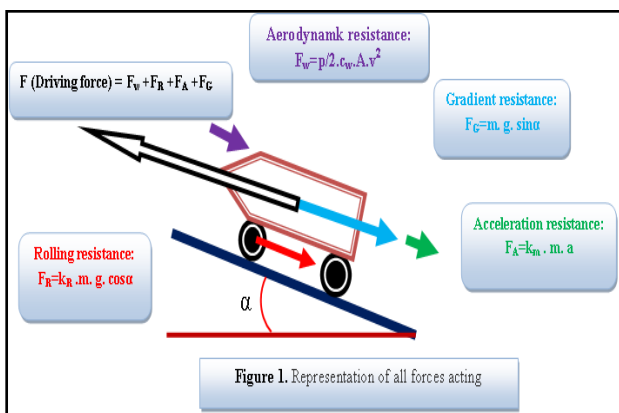

acceleration torque, $T_{permanent}$ permanent torque.

3. SYSTEM DESIGN

The structure of an electro-solar vehicle is a strong evaluating manner because of the more or less rapid but

steady evolution of the components technology and performance. As electric vehicles, the different parts are an emerging industry, it is necessary to set time constraints and objectives to be achieved at the level of performance cars, like to improve the acceleration performance of the vehicle. There have been remarkable developments in the area of solar cells and in the development of ultra light weight solar charging battery powered cars. The photovoltaic array could provide a large current in a short time, delivering extra energy to meet the energy requirement when it is needed. In addition, the electronics itself is an important constraint in terms of the shape of the car.

AutoCAD software is used to design the vehicle shape in order to choose the best frame vehicle shape and determining the weak points of the vehicle fig 2, fig 3[8]

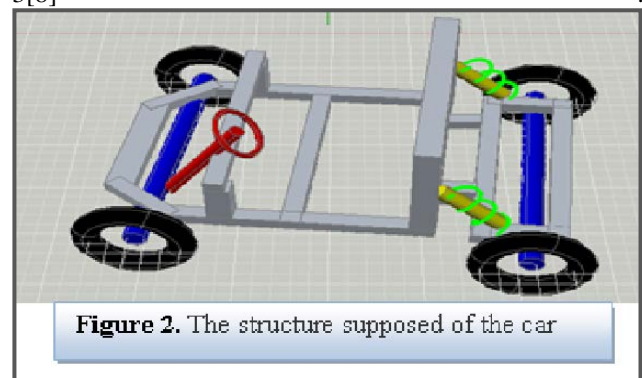

The front consists of a suspension system coupled with the

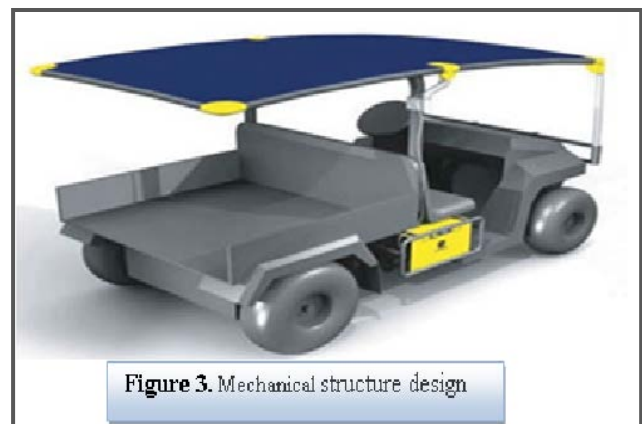

vehicle steering system. The suspensions will be considered "double wishbone": they will consist in two triangles, each of them is bound by two hinges one to the frame and the other ball to knuckle. These suspensions are similar to McPherson, often fitted to luxury vehicles or competition one, as they allow an infinite number of settings positions. The study has been divided into four parts:

- First, the double wishbone system have been designed and studied taking into account the expected load for four people,

then the tendering system management will be discussed, after the complete system will be designed to meet final

desired vehicle in terms of safety, functioning, robustness and cost, improvement will be forwarded to the end. The windshield should be made out of a substance with safety in brain.

4. MECHANICAL STRUCTURE DESIGN

This part allowed us to design our vehicle according to standards and technical regulations for Solar Electro Vehicles and the alternative energy imposed by FIA [9] and the equipment available in the market fig4, 5,6,7,8.



Figure 4. The structure of the car industry



Figure 5. The first car manufacturer



Figure 6. The second car manufacturer



Figure 7. Structure of the third car manufacturer



Figure 8. The third car manufacturer

5. ELECTRICAL DESIGN AND CONTROL

In this section all the vehicle elements involved in the energy management will be studied. Management strategies and algorithms will allow us to achieve out a control board, where it will make all the simulations needed for each party. And that, in order to have a reference for comparing the results obtained before and after test operations.

5.1 Solar Cells

The electronic part of this project consist to the objective of the electronic part is the contribution to the optimization of the powering of propulsive parts of the car from batteries powered by photovoltaic panels. Obviously, the major constraint that influenced the treatment of this part came from the settlement of the Solar Challenge of the City; the only source of energy powering the car is solar via battery.

Lead acid batteries called "starters" used in Electro-Solar Vehicle are not well suited to solar energy. In fact, they can be compared to "sprin-ters" to provide common significant start in a very short time (load and rapid discharge). "Solar" battery in turn, rather "Running" will be sought over time to common much lower and the technology is not quite the same (exchange surface

electrolyte / upper electrodes, in particular). Power resources performance at all levels of power; also it will be able to provide the full operation of the battery and motor. We will describe more fully the various bodies in the remainder of this work.

5.2 Influence of Temperature on Cell Efficiency

If the battery is charged directly instead of powering other devices, it is the battery voltage which requires the operation point of the PV panel. The I_{cc} current varies directly with the light radiation (the relationship is proportional) fig 9, the voltage remaining relatively constant. This is interesting, especially for the care of a battery, the temperature also has a significant influence on the characteristics of this panel .When the temperature rises, the voltage decreases and therefore the power too.

Note: that the variation is greater than that provided by simple variation of the exponential. Indeed, the term short circuit current is strongly temperature dependent. The curves in figures 4 and 5 show the drift characteristics this PV panel of crystalline silicon as a function of the temperature.

We see that we move more from an optimal power at 25°C at a deceased power for a temperature 45°C. It is therefore compelled to take into account the temperature of use of the photovoltaic cell in order to apply a reduction coefficient of the optimum at 25°C. Paradoxically, this disadvantage, in very hot climates, becomes an advantage in countries with temperate climate and high brightness fig 10.

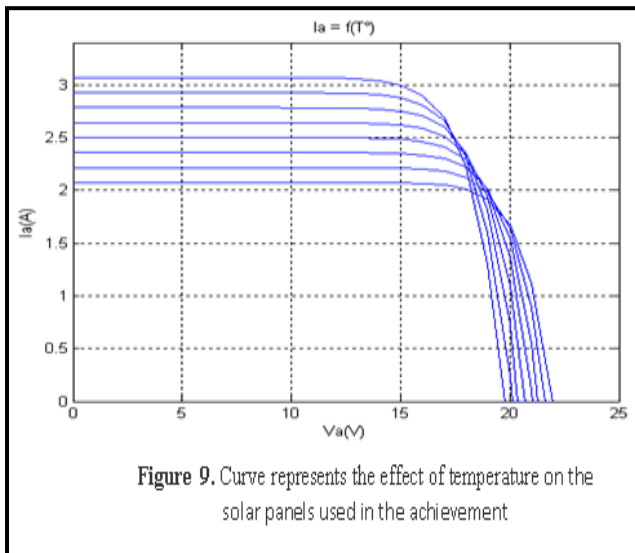

Figure 9. Curve represents the effect of temperature on the solar panels used in the achievement

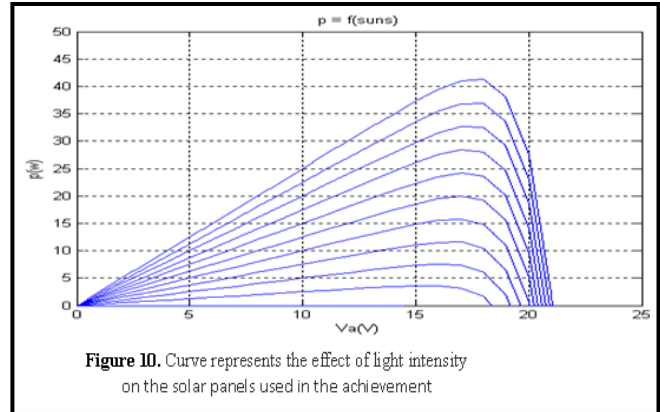

Figure 10. Curve represents the effect of light intensity on the solar panels used in the achievement

5.3 THE SYSTEM DESIGN

Real dimensions of the system are more complex, since there are many additional parameters to consider and many technology choices available. Each step of the design should always seek the best solution and must be performed by considering it with the other steps.

The sizing procedure of the system could be listed as following: Step 1: Identifying the needs: voltage, power and duration of use of equipment ... Step 2: Estimation of solar energy recoverable depending on the location; Step 3: Set the PV module: operating voltage, technology used, total power;

Step 4: Define the capacity and the choice of the battery;

Step 5: Selection of the charge controller; Step 6: Wiring diagram: sections of the cables,...

6. PART ELECTRONICS (PRACTICAL)

To ensure the effective operation and control of our vehicle, we used all our resources and knowledge. Like all parts of the vehicle fig 11.

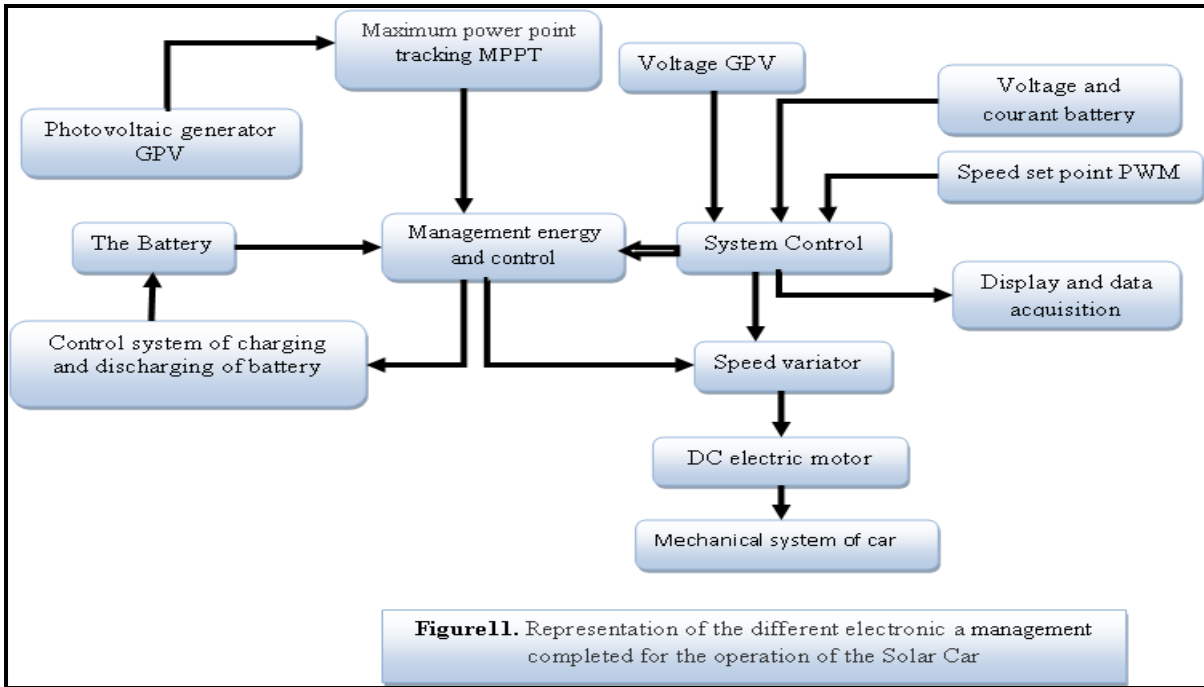

6.1

Practical Realization of the Electronics

For the implementation, we took into account the synoptic chosen for the desired operation; the failure of one affects all (fig 12).

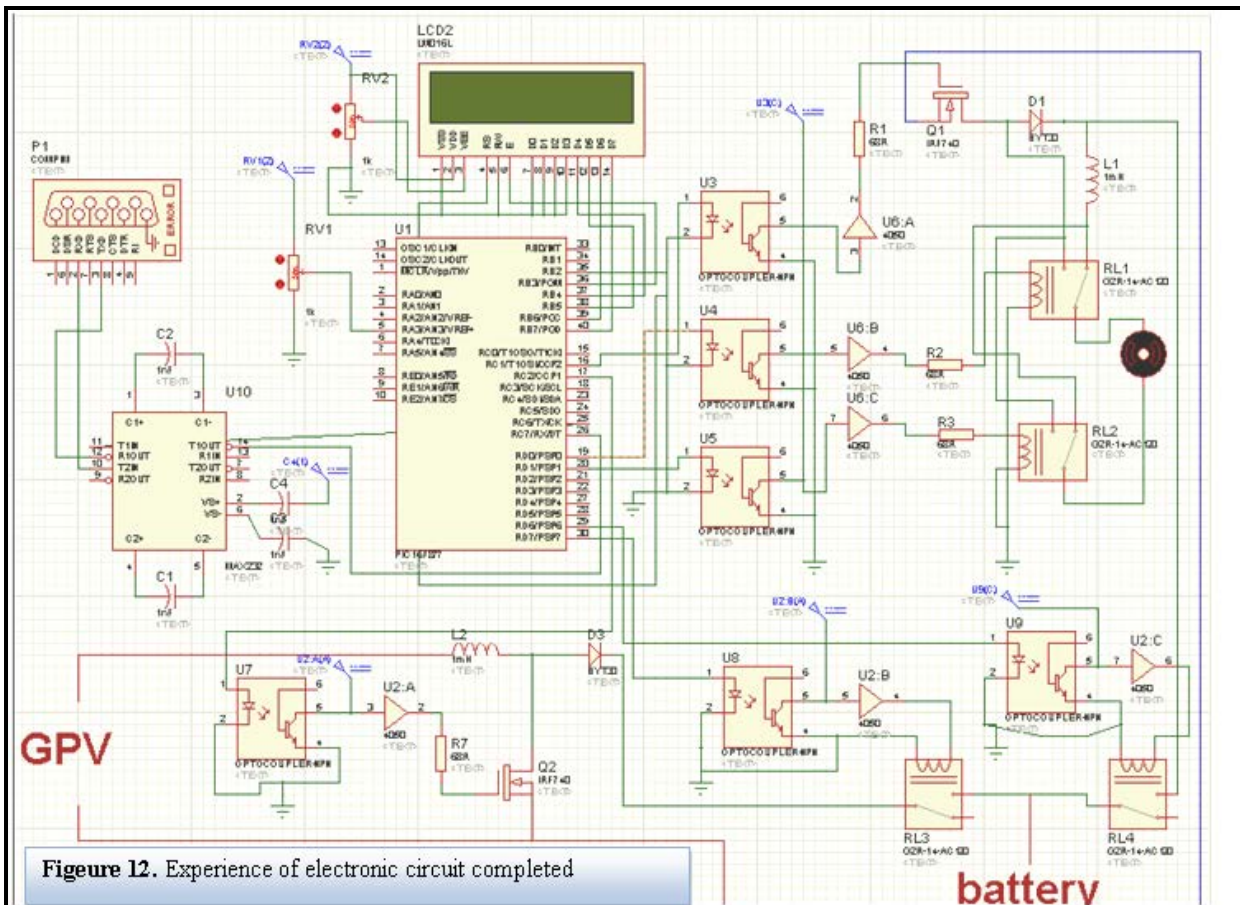

6.2 Operation of Circuit

The vehicle starts with battery mode to provide the current required, after that it rocks to mode panels. Research is going on to develop Brushless DC motor (BLDC motors)

as a prime mover for electric vehicles. These motors possess higher efficiency, lower weight and compact size as compared to others motors fig 13.

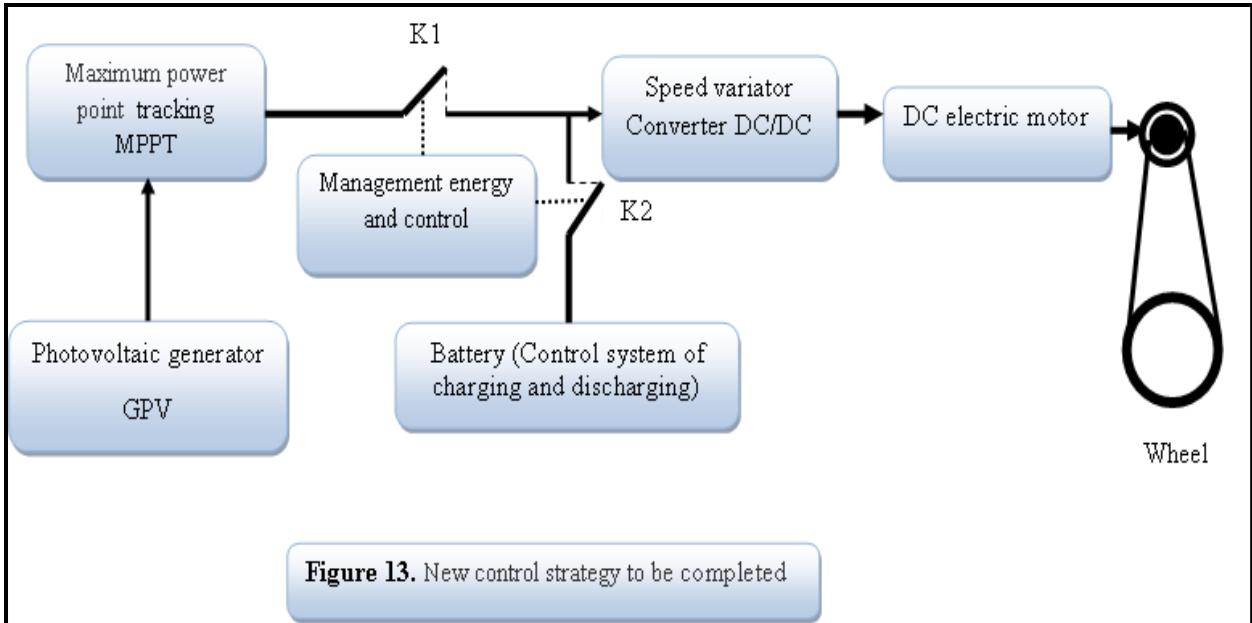

The Energy Manager provides load regulation and proper function of the vehicle. The operation manager is described as follows fig 14:

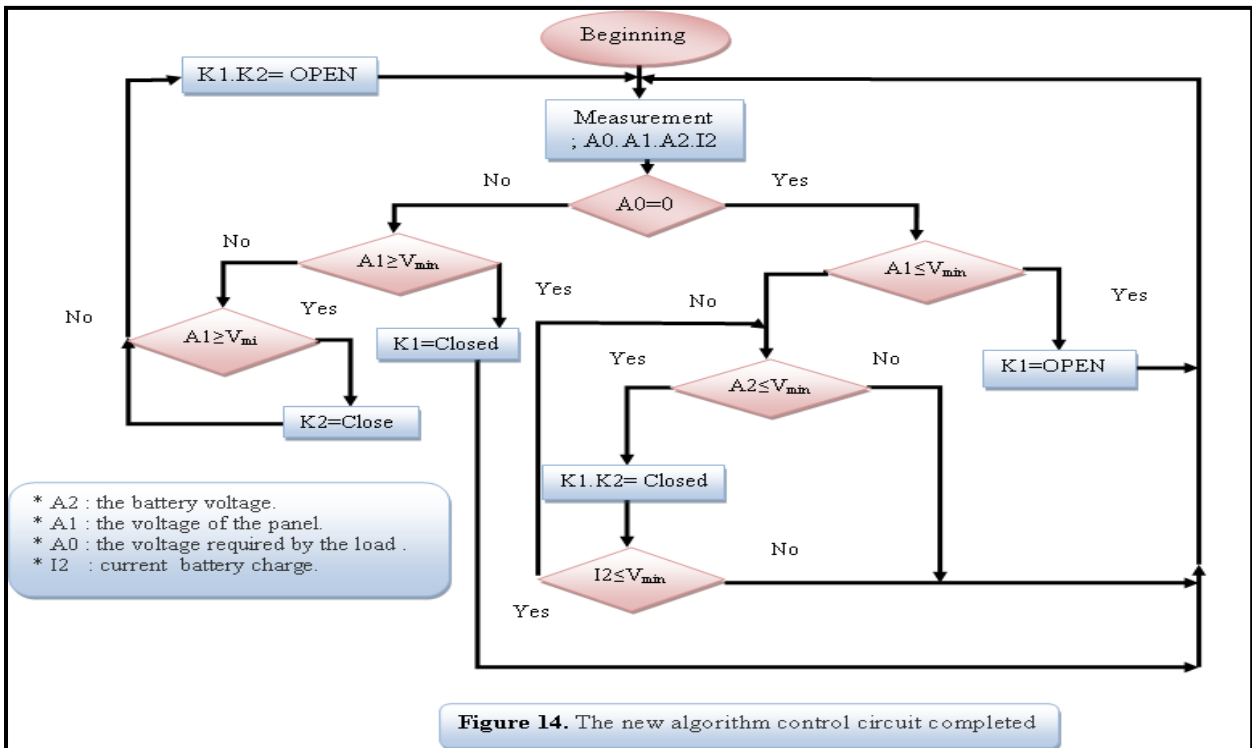

For the proper function of the manager is providing the following algorithm:

- The parameter A2 is the battery voltage;
- The parameter A1 is the voltage of the panel;
- The parameter A0 is the voltage required by the load parameter I2 current battery charge.

6.3 Energy Management of Charge

The energy management strategy aims to fulfill predetermined requirements with no knowledge of future driving conditions. The first step to design the energy management strategy is to define the global strategy

regarding the characteristics and constraints of the vehicle and the hybrid source

6.4 Mppt

The principle is simple, as we see on the next curve of the characteristic of power, depending on where one is on the curve fig 15, a small voltage change

($dV > 0$) implies either a positive or dI negative, and that's playing on these intensity variations that we will seek to achieve the maximum power point.

For this I have choose the following algorithm for achievement fig 16.

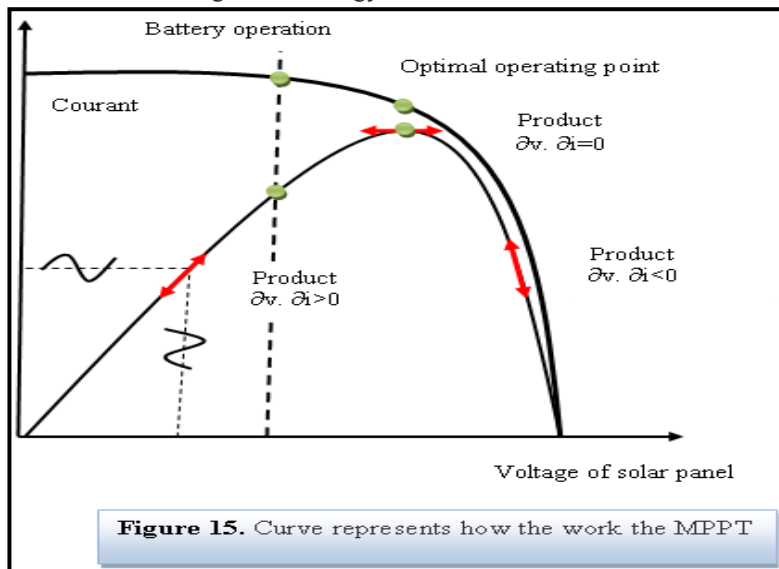

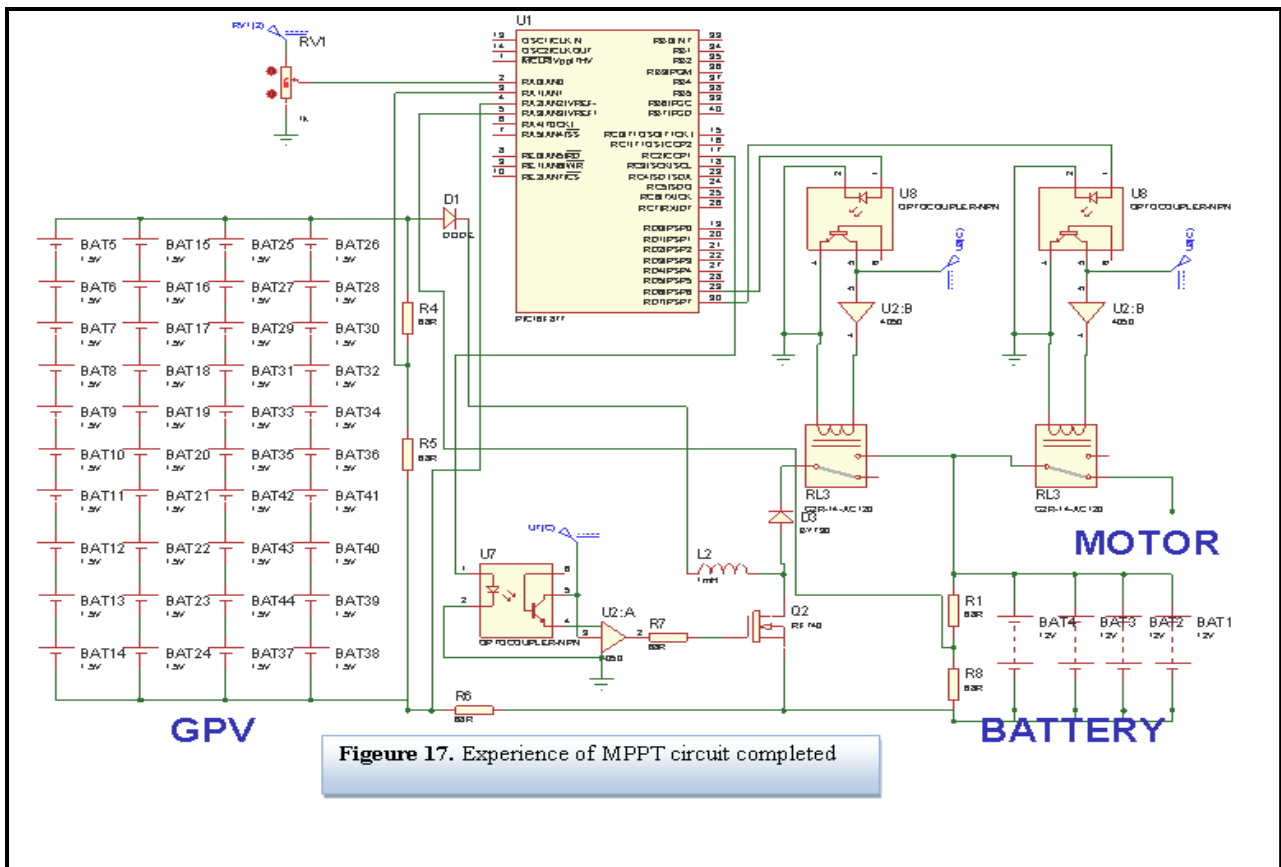
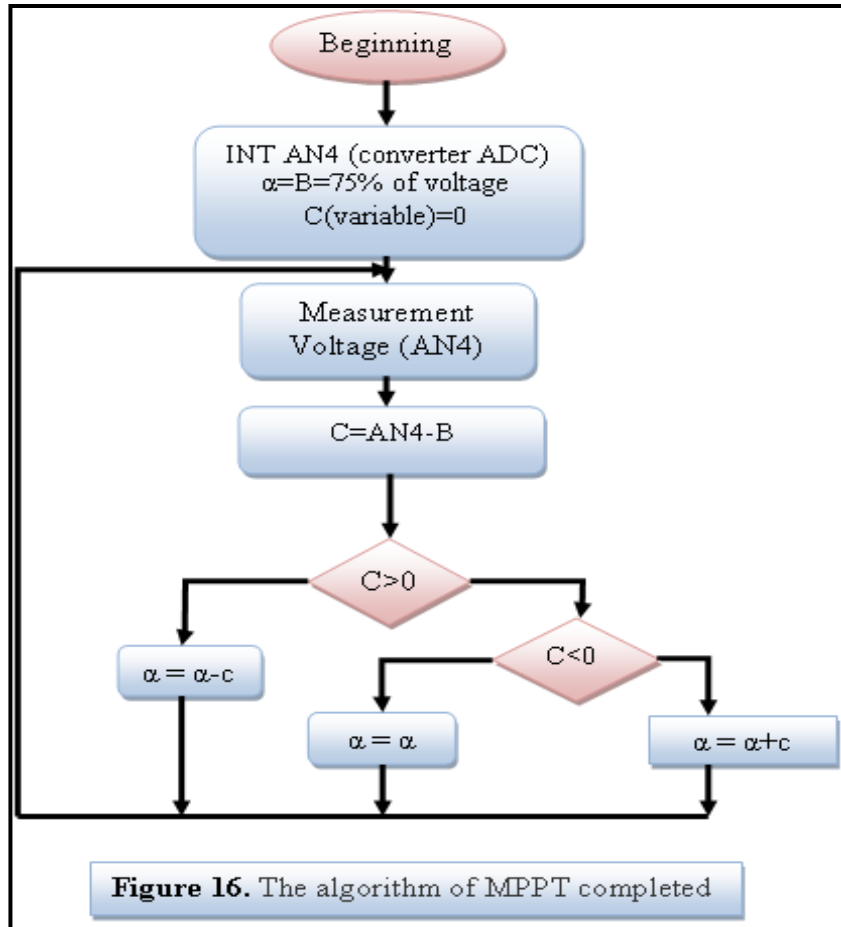

7. EMULATETHE WORK OFTHE CAR

In order to study the operation of the car four modes have been considered:

7.1 Case 1 no batteries

we have undertaken this study to see if we can use solar panels as the only source of energy fig 18 as we studied the effect of light intensity on the speed. Andin order to show the influence of light on speed fig 19, we have re-

simulated, and this time by using the intensity of light fig 20 constantly changing so the results were expected, where speedis directly related to the strong lighting consequently there was lack of control of the car. Consequently, we reached

the conclusion that we cannot use solar panels as the only source of energy, because to get the speed and capacity required to the work of the car, we need more surfaces of solar panels, which not available in this kind of use.

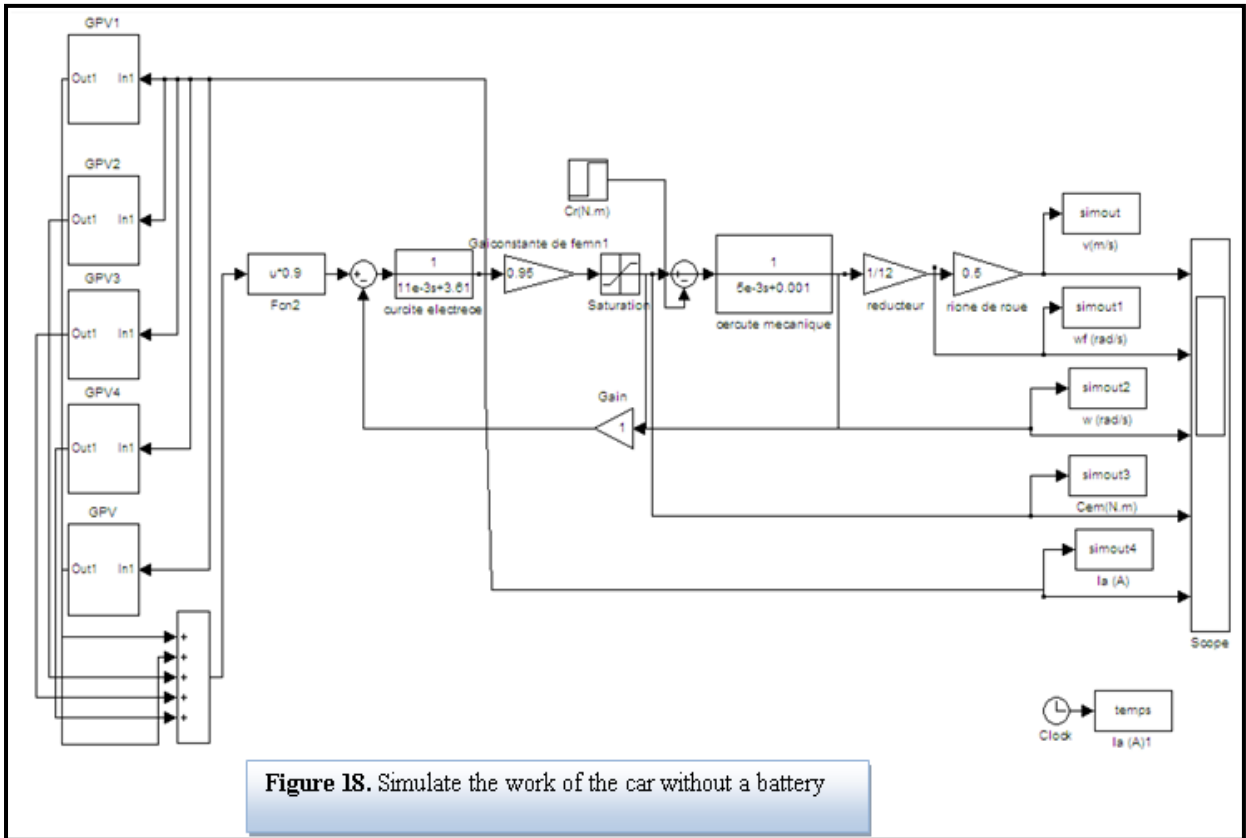

Figure 18. Simulate the work of the car without a battery

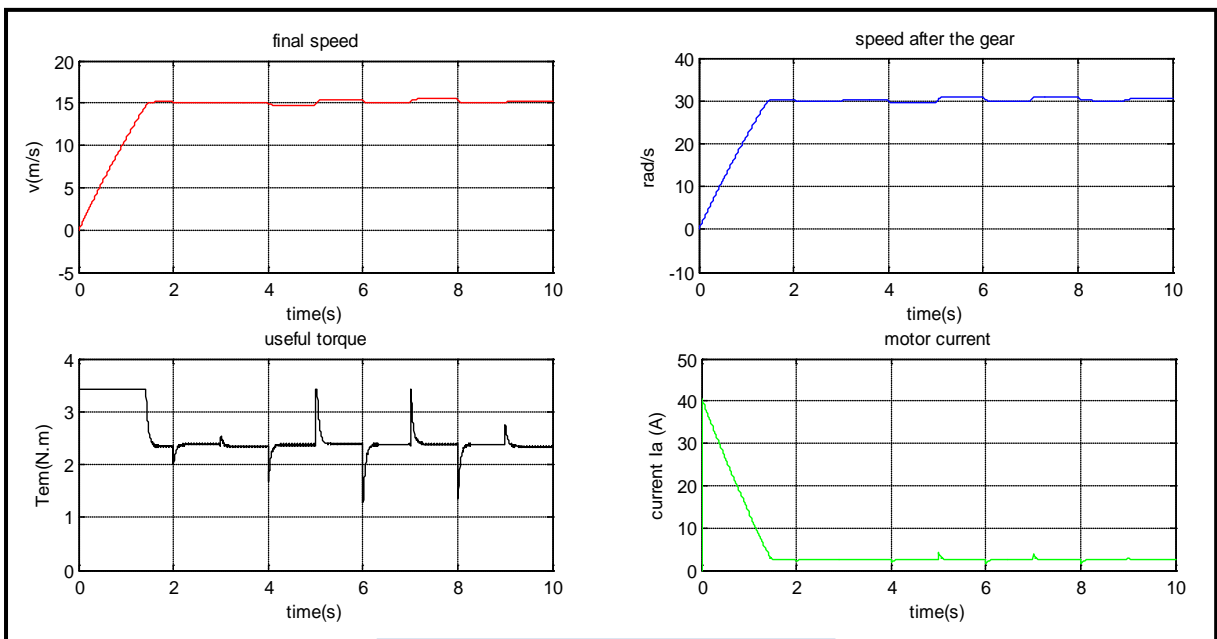

Figure 19 : Case no batteries

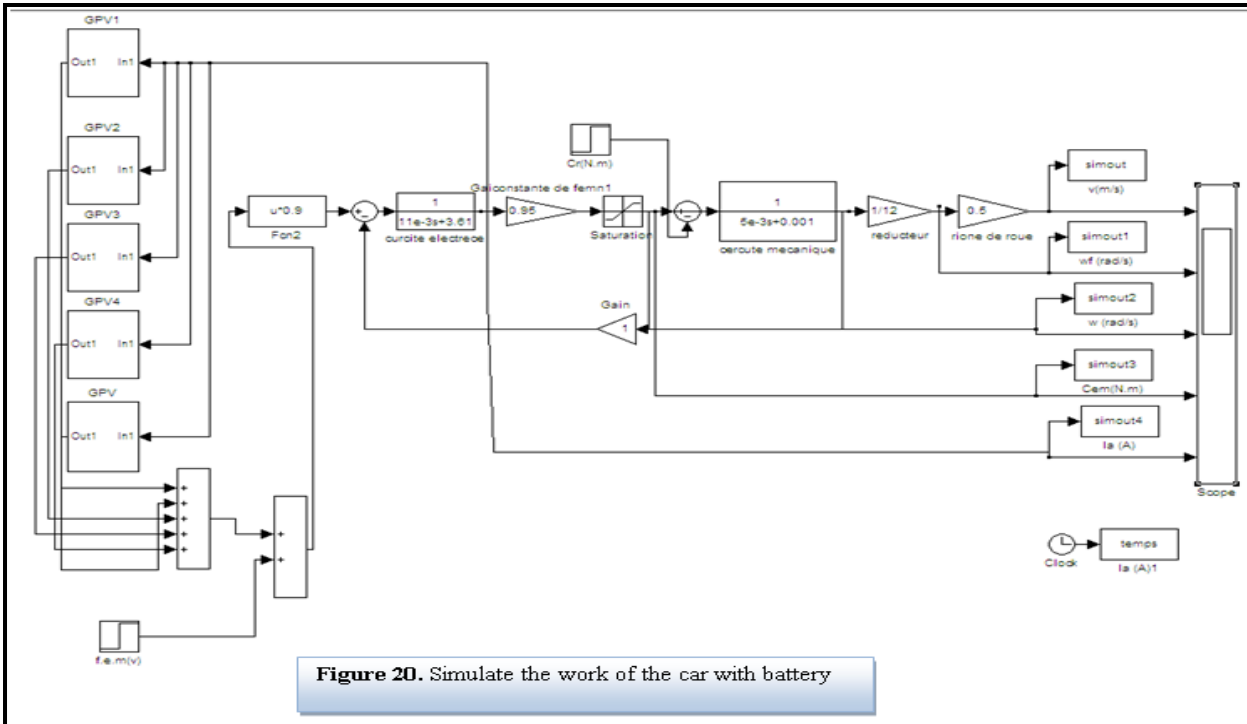

Figure 20. Simulate the work of the car with battery

7.2 Case 2 using the batteries

To solve the problem of changing the speed with changing the climate, we added another source of energy which the batteries fig 21.

Results were that the speed is not related to the climate, to confirm that we did the same simulations again and this time with all the possibilities of function of the car at the same time fig 22.

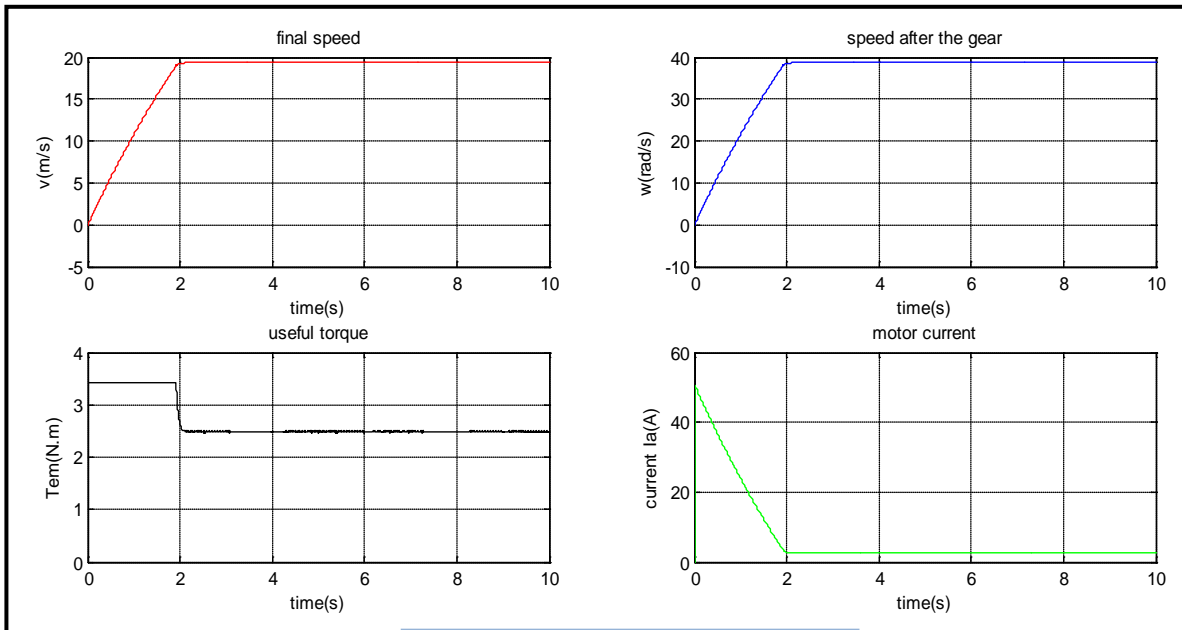

Figure21 : Case no batteries

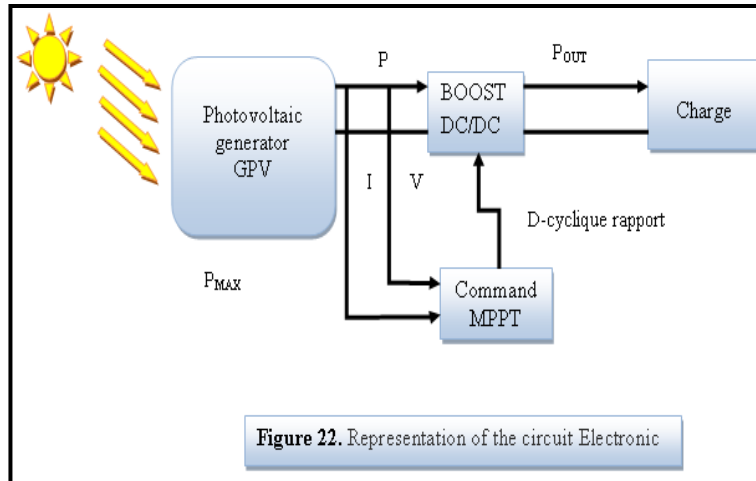

Figure 22. Representation of the circuit Electronic

We noticed that when the car works with batteries it becomes more stable, that the current flowing to the engines is directly related to required speed fig 23.

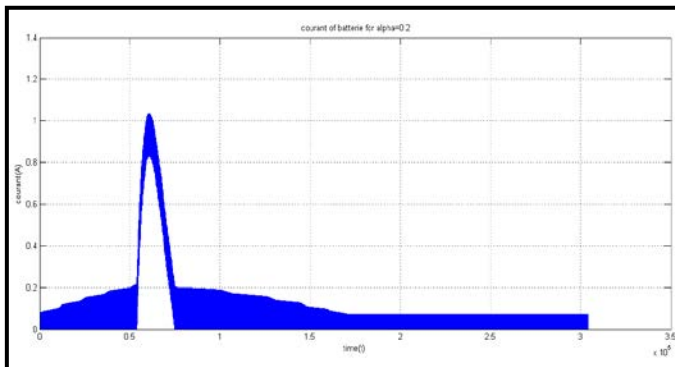

Figure23.Simulationsshow

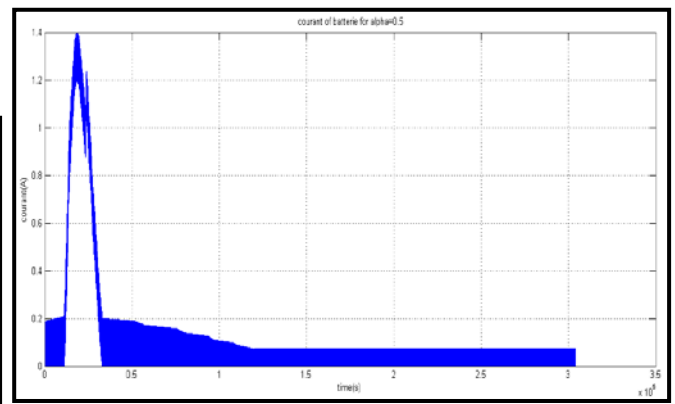

Figure24.Simulationsshowthe courant of the battery for alpha=0.5

7.3 In the case of solar panels and batteries

the situation was more stable, but cannot use this case in the application, because of the difference between the power panels and batteries, according to the total weight, size and maximum speed.

7.4 In the case of solar panels alone

we noticed that the work of the car is related to the factors outside the control, so it cannot be used in practice.

8. SIMULATION OF THE BATTERY CHARGE

This simulation is done by Matlab. We observed the voltage, current, changes in alpha (we took account of all the parameters of the assembly). Simulate the assembly is fig 24:

Notes

we noticed that in all cases the time required to charge the batteries is longer than the duration of the day light fig 25, 26, 27, this stresses that we cannot charge the batteries using the solar panels, and this according to the movement of the car and the charging time, space and the type of solar panels and its output, in relation to each case. In fact there must be another source to charge the batteries and there must be many batteries working in alternation.

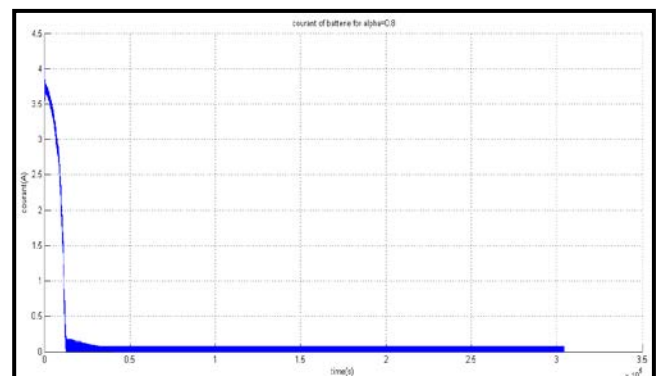

Figure25.Simulationsshowthe courant ofthe batteryfor alpha=0.8

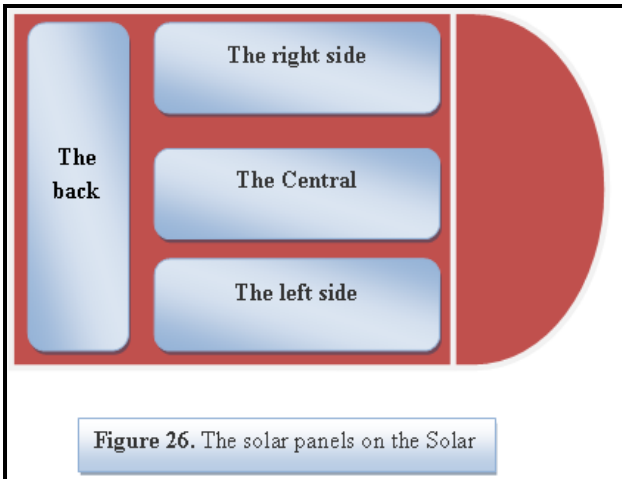

Figure 26. The solar panels on the Solar

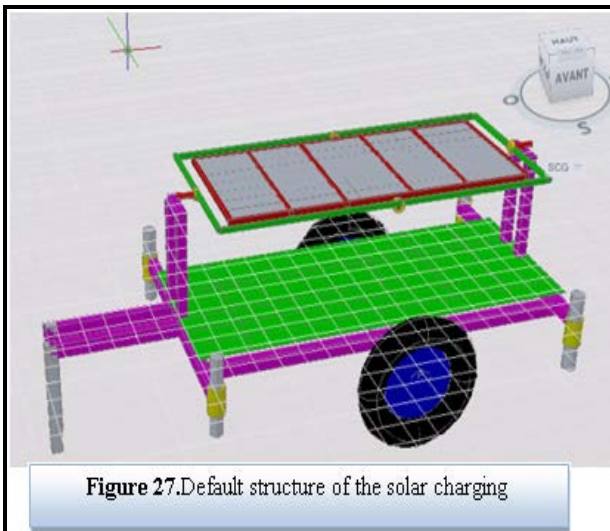

Figure 27. Default structure of the solar charging

9. CLASSIFICATION OF THE VEHICLE ACCORDING TO THE INTERNATIONAL STANDARDS OF THE INTERNATIONAL FEDERATION FOR CARS

We classified our vehicle according to technical criteria for solar power edvehicles in categories 1 and 4 in the weight class 1 and 8 in the categories of solar electric

propulsion vehicles, and meets the technical regulations of the fourth

10. COMPARISONS WITH OTHER DIRECTORS

If we would like to compare our car with others solar cars, it will better to know even if our car work fully with solar energy. If we look at the cars in the table we note that:

-Engine capacity is greater than the capacity which generate the solar panels, comparing with spacepanels allowed 8 m² (meters square), and the type of panels used.

-In addition to that, the place and the type of the panels does not allow us to use the whole space to produce greater power for energy, because we always have a part which does not produce energy. In the other hand, the solar rays are not perpendicular on the panels, and that decrease its efficiency.

-As well as the battery's type and its capacity; indeed we conclude that the cars are electric -use the batteries to work, the evidence is the total weight and speed and the impossibility to charge the batteries using solar panels only.

-In all cases the time required to charge the batteries is longer than the duration of the day light, this stresses that we cannot charge the batteries using the solar panels, and this according to the movement of the car and the charging time.

Consequently they are not considered as solar cars. And we consider that our results are positive.

11. PROPOSED SOLUTIONS

in order to solve the problems we have the following * the separation of the solar panels from the car and put it in a fixed place fig 29, and make the car work with batteries which, in turn, are charged using solar panels.

For industrialization Follow the following chart fig 30.

This is the unit manufacturer fig 31, 32.

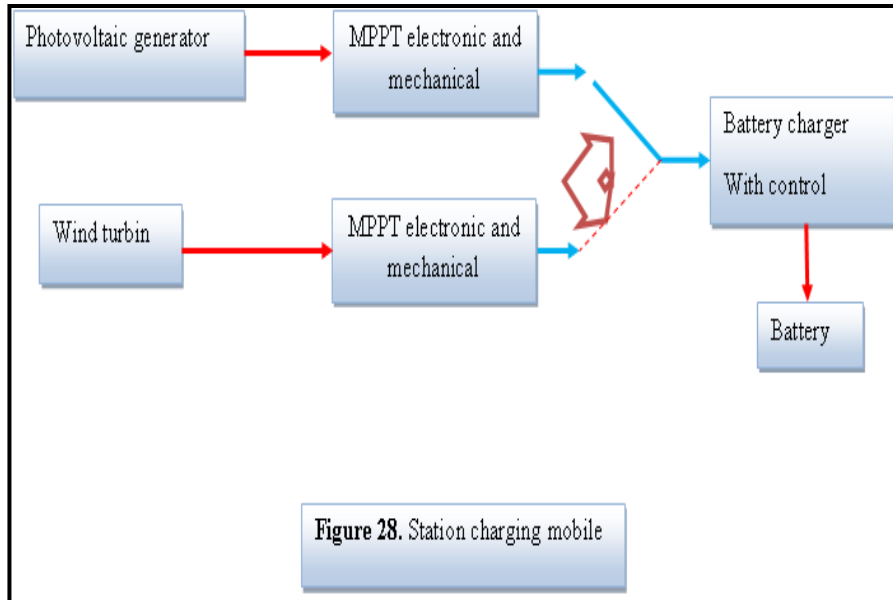
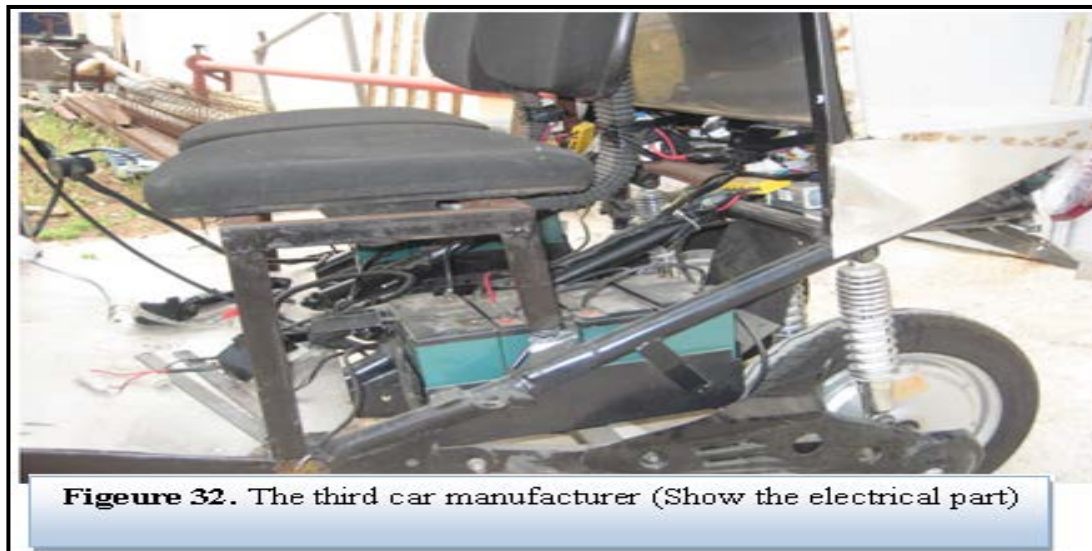
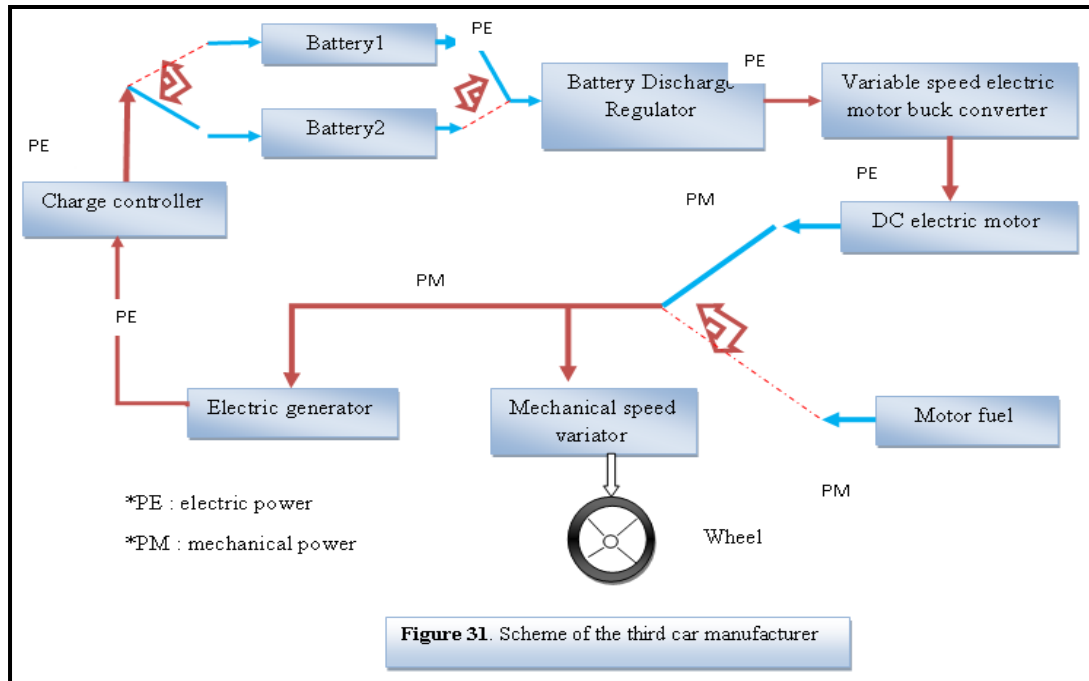

Figure 29. Solar charging unit manufacturer (The front face)



Figure 30. Solar charging unit manufacturer (Back flip)



*As for the time of loading, we've run out of the batteries which are replaced by others charged with solar panels and let the empty to be charged fig 33. The following plans show the mechanism used fig 34.

*We are in the process of experiments in order to replace the batteries by a generator working with the free energy.

12. CONCLUSION

These works aim to design and construct a solar vehicle. This type of engine can be used in open cities (industrial, tourism, golf courses ...). The objective of this work is to achieve a fully autonomous vehicle that is powered by a solar power system equipped with a secondary battery. Our motivations for this project were numerous, but most important was that it is a laboratory for our first confrontation against the design and implementation of such a vehicle.

The implementation of this work needs to study the mechanical and electronic parts; the results obtained are the means for their integration and observation the correlation between them to start up our vehicle. The constraints of this project were numerous. First, it is not easy to build a solar car with little experience; we have established ourselves to achieve a light vehicle and energy optimization. This work was divided into an electronic part and a mechanical part. To do this, we presented the theory, technical problems; the solutions which we thought to solve them, and especially the solutions that we have chosen. But this view was also intended to be reusable, so that our work and our research conserve in the coming years and bring the team to EPES why not win a challenge sun.

A sleek, professional electric vehicle conversion will provide satisfying, economical, and environmentally-friendly transportation.

REFERENCES

- [1] H.C. Lovatt , V.S. Ramsden , B.C. Mecrow “Design of an in-Wheel Motor for a Solar-Powered Electric Vehicle”. IEE Proc-Electr. Power Appl., Vol. 145, No. 5, September 1998, pp 402-408.
- [2] CARICCHI, F., CRESCIMBINI, F., HONORATI, O., DINAPOLI, A., and SANTINI, E.: “Compact wheel direct drive for EVS”, IEEE Ind. Appl. Mag., 1996, pp. 25-32
- [3]. G. Guo Dong , G. Yu Han, L. Chee Ken , “studies of electric motors for light-weight electric vehicle”. Proceeding of Malaysian Universities Transportation Research Forum and Conferences 2010 (MUTRFC2010), 21 December 2010, Universiti Tenaga Nasional. ISBN 978-967-5770-08-1 pp.135-148
- [4] J.Connors, “Telemetric development in solar vehicles with synplify pro software,” The Syndicated, vol. 5, no. 1, pp. 1,3–5, 2005.
- [5] K.D.Huang, S.-C. Tzeng, W.-P. Ma, and M.-F. Wu, “Intelligent solarpowered automobile-ventilation system,” Applied Energy, vol. 80, pp.141–154, 2005.
- [6] A. Riisnaes, C. Allen and P. Winkler. ““Dakota Sun” The Next Generation Solar Powered Racing Vehicle”. IEEEAES Systems Magazine, November 1996. Pp.3-6.
- [7] N. Mutoh, Senior Member, IEEE, and T.Inoue “A Control Method to Charge Series-Connected Ultraelectric Double-Layer Capacitors Suitable for Photovoltaic Generation Systems Combining MPPT Control Method”. IEEE TRANSACTIONS ON INDUSTRIAL ELECTRONICS, VOL. 54, NO. 1, FEBRUARY 2007. Pp.374-383.
- [8] <http://www.google.fr/imgres?imgurl=http://webecoist.momtastic.com/wp-content/uploads/2008/11/10-solar-powered-golf-cart->
- [9] Règlement Technique Energie Alternative / Alternative Energy Technical Regulations. FIA Sport / Technical Department. 11.12.2006
- [10] Techniques d'ingénieur (Conversion photovoltaïque de la cellule aux systems par Stéphan ASTIER)