

Electric Vehicle Speed Control using Three Phase Inverter operated by DSP-based Vector Pulse Width Modulation Technique

Saidi Hemza¹, Nouredine Mansour², Midoun Abdelhamid³

^{1,3}Electrical Engineering Department, Mohamed Boudiaf University of Science and Technology, Oran, Algeria; E-mail: h.saidi@univ-chlef.dz

²College of Engineering University of Bahrain P.O. Box 32038, Kingdom of Bahrain
E-mail: nmansour@uob.edu.bh

Abstract-Solar electric vehicles (SEV) are considered the future vehicles to solve the issues of air pollution, global warming, and the rapid decreases of the petroleum resources facing the current transportation technology. However, SEV are still having important technical obstacles to overcome. They include batteries energy storage capacity, charging times, efficiency of the solar panels and electrical propulsion systems. Solving any of those problems and electric vehicles will compete - complement the internal combustion engines vehicles. In the present work, we propose an electrical propulsion system based on three phase induction motor in order to obtain the desired speed and torque with less power loss. Because of their lightweight nature, small volume, low cost less maintenance and high efficiency, a three phase squirrel cage induction motor (IM) is selected for the electrical propulsion system. The IM is fed from three phase inverter which is operated using constant V/F control method and Space Vector Pulse Width Modulation (SVPWM) algorithm. The proposed system uses Texas Instruments TM320F2812 Digital Signal Processor (DSP) to generate SVPWM signal needed to trigger the gates of IGBT-based inverter. The experimental results show the ability of the proposed system to generate a three-phase sine wave signal with desired frequency. The system is also experimented on EV prototype which we manufactured and the results show that the EV prototype can be propelled to speed up to 60 km/h under different road conditions.

Key Words- Electric Vehicle, Squirrel Cage Induction Motor, SVPWM, V/F control, DSP processor, DMC library.

1 Introduction:

Efforts to improve air quality in heavily populated urban communities- by reducing vehicular emissions – have rekindled interest in the development of electric vehicle technology. However, the key issues which are challenging the design of electric vehicles are the electric propulsion system, energy sources and battery management system [1, 2]. Solving any of those issues and electric vehicles will compete - complement the conventional internal combustion engines vehicles. This paper will focus only on the electric propulsion system design.

DC and BLDC motor drives have been widely applied as propulsion system to EVs because of their technology maturity and control simplicity. However, with the emerging technology in switching semiconductors and digital signal processors at reasonable cost led to more interest in using AC induction motors instead of DC motor [3]. The AC induction motors especially the cage type, have lightweight, small volume, low cost, less maintenance, no commutation, high torque at low speed and high efficiency. These advantages are particularly important for EV applications.

As EVs propulsion, an AC induction motor drive is fed with a DC source (battery), which has approximately constant terminal voltage. Thus a variable frequency and variable voltage DC/AC inverter is needed to feed the induction motor [4]. The DC/AC inverter is constituted by power electronic switches and power diodes. The current generation of inverter is based on high speed power transistors, like IGBT and MOSFET.

Since the output of the inverter is a high frequency square wave, a high speed processor is needed to produce the proper switching sequence. Various switching techniques [5] are used

to generate PWM signal which is used to determine the amplitude and the frequency of the output voltage. Among the various PWM techniques, Space Vector Pulse Width Modulation (SVPWM) has advantages that made it the most switching techniques suitable for electric vehicles. The interesting features of this type of modulation is that it provides better DC-link utilization, more efficient use of DC supply voltage, produce less ripples and increase life time of drive [6]. It can be easily implemented digitally and hence offer the advantage to perform entire digital processing. The performance of SVPWM depends on the type of processor used for its implementation. Among the various processors available in the market, the most popular are the Texas Instrument DSP which holds about 70% of the market [8]. TMS320F2xxx DSP series are high speed processors which have been developed by Texas Instruments especially for industrial control applications, in particular for implementation of SVPWM algorithm to drive the switches of the inverter.

Since the vehicle speed can be monitored by the driver and desired speed can also be adjusted by the driver an open loop control with constant voltage/frequency (V/F) method is implemented to control the speed of the motor. The V/F is selected because it tries to achieve some features which are suitable for electric vehicles. These include wide speed span with constant motor torque, low starting current, acceleration and deceleration of the vehicle.

The objective of this study is to develop an electric propulsion system based on three phase squirrel cage induction motor, IGBT-based three phase inverter and advanced processor, such as DSP, implementing SVPWM algorithm for open loop speed control using V/F method of electric vehicle. The paper is organized as follows: first we discuss the SVPWM technique along with V/F method, second we discuss the mechanical part of the vehicle, and third we describe the electrical propulsion system and finally practical results obtained are presented along with conclusions.

2 Space Vector Pulse Width Modulation Techniques:

A number of Pulse width modulation (PWM) schemes are used to control the magnitude and frequency of AC output voltage of the inverter. The most widely used PWM schemes for three-phase voltage source inverters [7] are sine wave sinusoidal SPWM and space vector PWM (SVPWM). Since SVPWM is easily implemented digitally, enable more efficient

utilization of DC bus voltage, and generate sine wave with lower total harmonic distortion, it is most frequently preferable technique used in modern AC machines drives fed by inverters. The performance of an induction motor is improved when SVPWM technique is applied [6]. Details explanation of the SVPWM and SPWM techniques can be found in [7]. Although SVPWM is more complicated than sinusoidal PWM, it is easily implemented using modern DSP based control systems. The SVPWM technique implemented into the existing TI Digital Motor Control (DMC) library reduces computation time and the number of transistor commutations [9, 10]. It therefore improves EMI behavior.

In this work, the constant voltage/frequency (V/F) method along SVPWM is used for open loop speed control of induction motor with a reasonable degree of accuracy.

3 V/F control method

The best way to vary the speed of the induction motor is by varying the supply frequency. It can be shown that the torque developed by the induction motor is directly proportional to the ratio of the applied voltage and the frequency of the supply [4]. By varying the voltage and frequency, but keeping their ratio constant, the torque developed can be kept constant throughout the speed range. In summary, using the V/F control method the following can be achieved: 1) the induction motor can be run typically from 5% of the synchronous speed up to the base speed (maximum vehicle speed), and the torque generated by the motor can be kept constant throughout this range; 2) the starting current is lower; 3) the acceleration and deceleration can be controlled by controlling the change of the supply frequency to the motor with respect to time.

4 Design objectives:

The dimension and mechanical structure of the electric vehicle prototype manufactured and used in this study is shown in figure 2. The weight, volume and aerodynamic drag and rolling resistance effects have been carefully considered in the design of the body of the vehicle [11]. The design objectives are to attain maximum speed of 60 km/h with a total weight of 500 kg and acceleration time 0 to 60 km/h below 30 sec. Figure 1 is used to derive the desired driving power to ensure vehicle operation.

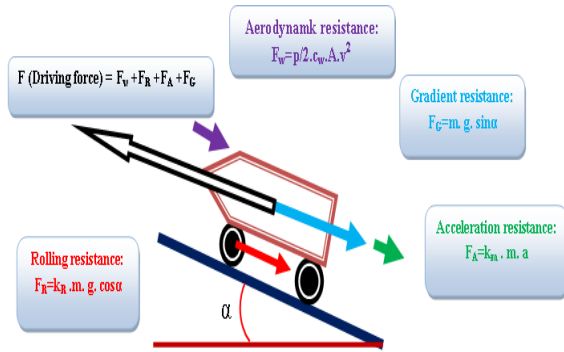

Figure 1: Representation of all forces acting on EV

The road slope torque T is defined by:

$$T_w = \frac{P}{2 \cdot c_w \cdot A \cdot v^2} \quad (1)$$

$$T_R = k_R \cdot m \cdot g \cdot \cos \alpha \quad (2)$$

$$T_A = k_m \cdot m \cdot a \quad (3)$$

$$T_G = m \cdot g \cdot \sin \alpha \quad (4)$$

$$T = T_w + T_R + T_A + T_G$$

Where; T_w is aerodynamic torque, T_R : rolling torque, T_A acceleration torque and T_G gradient torque.

Torque evaluation of the power flow occurring into a vehicle is in strong relation with its mass and a total couple will be expressed as:

$$C_t = T_A + T_p \quad (5)$$

Where; m is a vehicle mass, C_t total torque, T_A acceleration torque, T_p permanent torque, α road angle.

For this study, we selected for the EVs propulsion a cage three phase induction motor of 4.7 kW 220/380 V 11/19 A with maximum speed of 1500 rpm. The solar panel station to refuel the vehicle batteries are shown in figure3.



Figure 2: Photo of the vehicle manufactured



Figure 3: Photo of the solar charging unit

5 Description of the Electrical Propulsion System

Figure 4 shows the block diagram of the open loop control system used to adjust the speed of the vehicle. The hardware includes squirrel cage induction motor, bridge inverter, isolation card, Digital Signal Processor (DSP), speed sensor, potentiometer for desired speed adjustment, and switches for user interface. The desired speed is entered by the user via the potentiometer and then entered to DSP via analog to digital converter (ADC). The speed of the motor (i.e. vehicle) is monitored using tachometer.

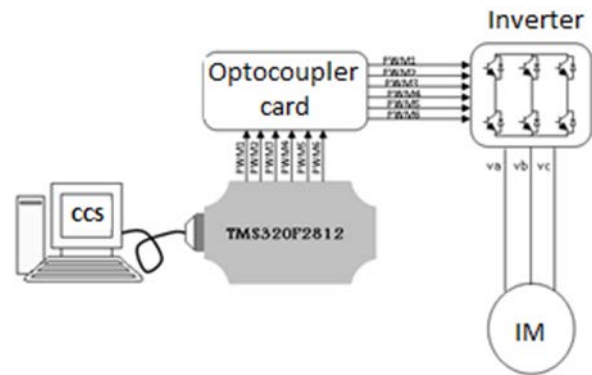

Figure4:The block diagram of the open loop control system.

6 Hardware and Software Specifications:

6-1 Digital Signal Processor (DSP): it is a 32-bit 150MIPS TMS320F2812 DSP developed by Texas Instruments Inc. The most widely used Code Composer Studio (CCS) developed by TI is selected to program the DSP to generate PWM signals. The CCS disposes of Digital Motor Control (DMC) library which reduces significantly the time and effort required for programming the DSP[8]. The

DMC library provides software modules which are dedicated for motor control. The main software modules used in our project are: VHz_PROF, SVGEN_MF and PWMGEN.

6-2 Isolation Card it is used: to ensure the necessary galvanic isolation between DSP and power inverter. The card is realized using HCLP 2601 rapid optocouplers. In addition to the galvanic isolation, the card realized provides also signal inversion and amplification (Figure 5)

6-3 IGBT-based Three Phase Inverter: It is an International Rectifier's IRAMY20UP60B type 20A, 600V Integrated Power Hybrid IC (HIC) with Internal Shunt Resistor for motor drives applications.

It is a compact, high performance AC motor-driver in a single isolated package which simplifies design. A built-in temperature monitor and over-current and over-temperature protections, along with the short circuit rated IGBTs and integrated under-voltage lockout function, deliver high level of protection and failsafe operation. Using a single in line package with heat spreader for the power die along with full transfer mold structure minimizes PCB space and resolves isolation problems to heat sink [12]

6-4 Three Phase Squirrel Cage induction Motor

4.7 KW, 3 phase, 220/380V, 11/19A, 1500 rpm, eight Lead Acid gel-type DC batteries(12v/48Ah) and fivesolar panels(500w/120v).

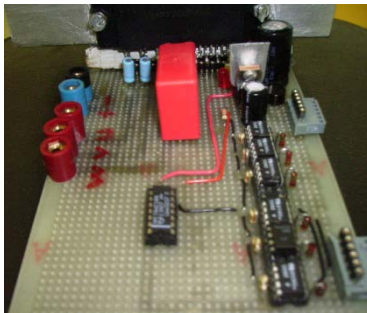

Figure 5 Galvanic isolation card realized

7 Open Loop Control Strategy

The user adjusts the desired speed using a potentiometer and this latter converts it to its analogous voltage. The output of the potentiometer is sensed by the ADC which is integrated on the DSP and then converted to desired frequency F_s . The open loop control program consists of several stages as shown in the flow chart depicted in figure 6. Based on the figure, the open loop system can be summarized as follows:

- Initialization DMC modules and declare variables

- Determine V_s voltages with constant V/F profile based on desired frequency (F_s) using VHz_PROF module.
- Determine the time durations T_a , T_b and T_c based on V_s and F_s using SVGEN_MF module.
- Generate the signal PWM based on the time durations T_a , T_b and T_c using PWMGEN module.

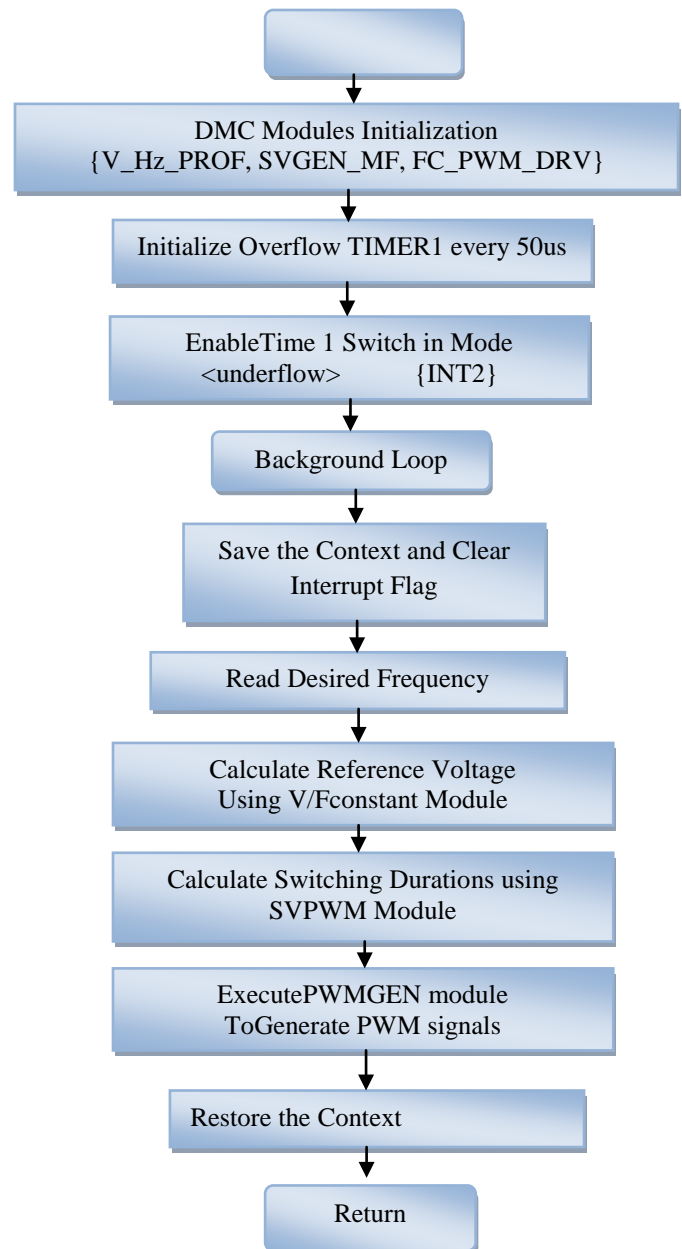

Figure 6: Program Flow Chart

8 Practical Results:

Figure 7 shows the PWM signals generated by the SVPWM module after the execution of the program implemented in the DSP. Figure 8 illustrates the two PWM pulses which are complementary and used to trigger the gates of one leg of the IGBT Bridge of the inverter. As shown in figure 8, in order to avoid the short circuit of inverter power supply, we introduced a time delay of $0.5 \mu s$ between the two complementary pulses.

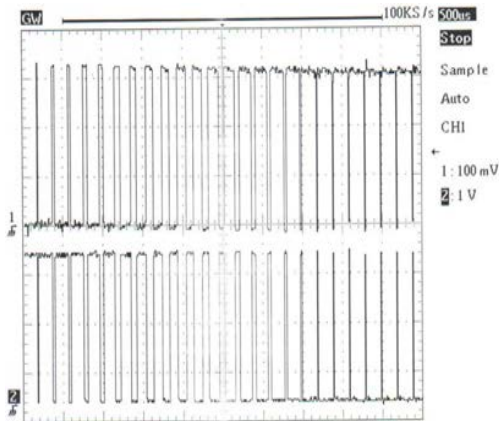

Figure 7: PWM signal and its complement.

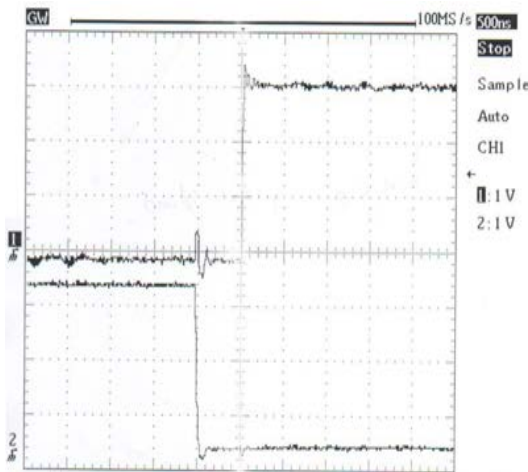

Figure 8: Dead time between two complementary pulses.

Figure 9 shows PWM signals before and after the optocoupler card which ensures galvanic isolation between DSP and Inverter. As shown in figure 9, the PWM signals of magnitude 3.3 volts generated at the DSP output are inverted

and amplified to 5 volts by the optocoupler card before inputting them to the inverter.

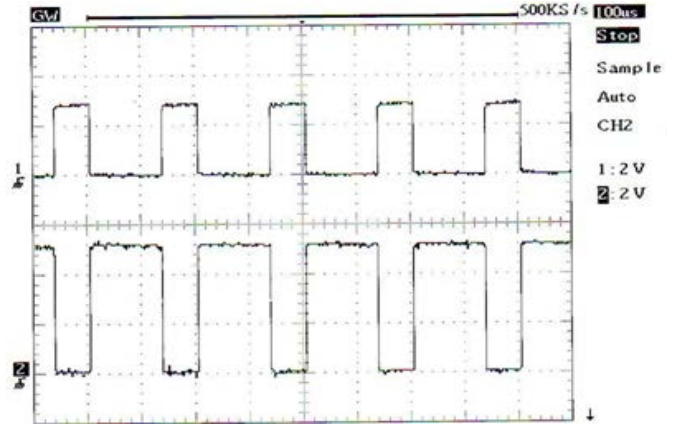

Figure 9: PWM signals before and after optocouplers.

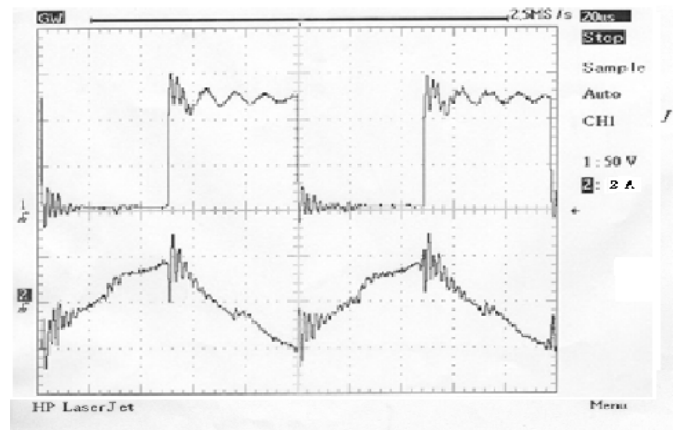

Figure 10: Current waveform and voltage waveform at the switching of a cell.

To check the switching behavior and the reliability of the inverter (i.e. IR IRAMY20UP60B module), we investigated the operation of one of its cell during commutation. Figure 10 illustrates the waves of current and tension for an IGBT cell under RL inductive load with $R=8.4 \Omega$ and $L=4.75 \text{ mH}$ during commutation. The switching frequency of the IGBTs transistors and DC power supply voltage are 10 kHz and 160 V respectively. As shown in figure 10, the current increases in continuous form from 0 to 5 A during switching off (Switch Open) and then decreases back to 0 A during switching on (Switch Close). The voltage across the switch is equal to the DC power supply. Figure 10 shows small current spikes and voltage ringing during switching which are probably due to the IGBTs internal parameters.

The inverter is tested to supply induction motor with rating 4.7KW with and without load. This motor is the one selected to be used in the propulsion system designed. The switching frequency of the IGBTs transistors and DC power supply voltage are 10 kHz and 200 V respectively. Results illustrated in figure 11 and 12 show the current and line to neutral voltage at the inverter output when supplying the motor. As can be noticed, the results are very satisfactory and the current wave is almost sinusoidal. Figures 11 and 12 also show the ability of the inverter changing speed of the motor (i.e. Vehicle) by generate sinusoidal voltage for different desired frequencies (i.e. 25 Hz and 50Hz).

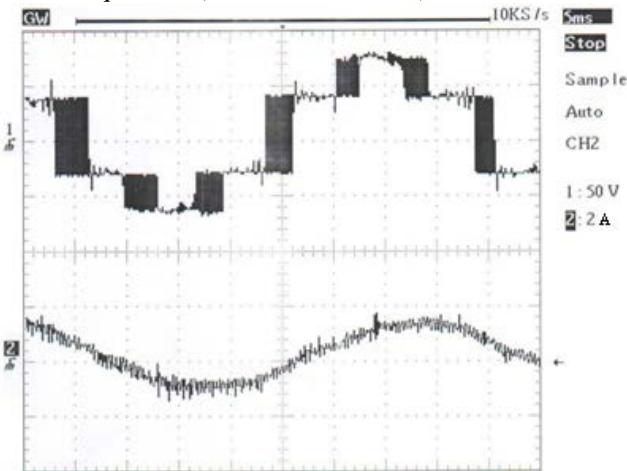

Figure 11: waveform of the phase voltage and current for $f = 25\text{Hz}$ with a load torque.

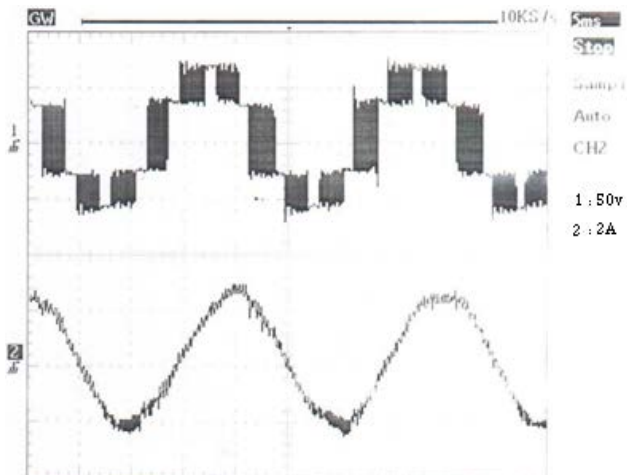

Figure 12: waveform of the phase voltage and current for $f = 50\text{Hz}$ with a load torque.

Finally, we investigated the practical performance of the electric propulsion system designed under road load. The vehicle has been operated on flat road and we started changing its speed at different stages. The results obtained are very satisfactory as shown in figure 13. The speed is increased progressively by the driver and the maximum speed reached is more than 60 km/h (i.e. 19.5 m/s) and the current required at this speed is 3.5A. The results show that the vehicle can reach speed up to 90 km/h. However, driving at this speed resulted in lot of vibrations of the vehicle. This is probably due to the incomplete design requirements of the vehicle body [11].

The capability of the electric propulsion system under overload was also investigated by operating the vehicle on graded road condition where the road grade angle is about 45 degree. The results are shown in figure 14. The speed reached in this case is about 12.7 m/s (i.e. 45 km/h) and the current required is 5.8 A.

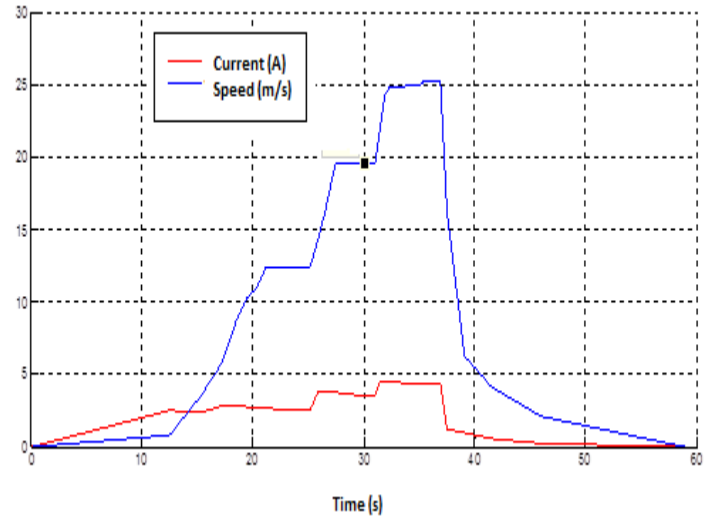

Figure 14: Running the vehicle in flat road.

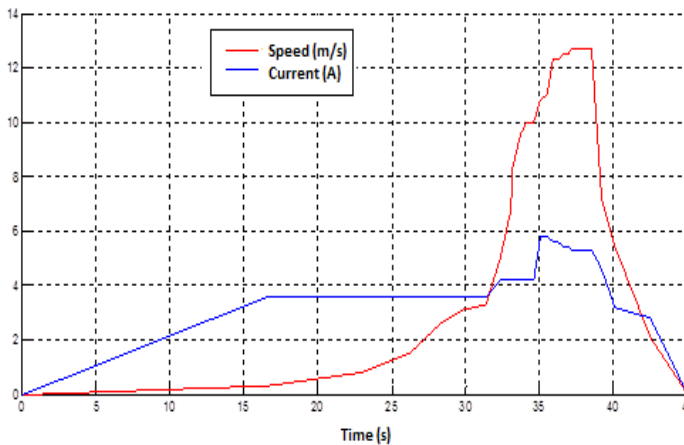

Figure 14: Running the vehicle in a graded road.

9 Conclusions

The paper presents design of a battery electric vehicle which is propelled by three phase cage induction motor and powered by solar energy station. After several experiment performed, we demonstrated that the DSP-based control system developed is able to operate the vehicle at different speeds under flat and uphill road condition. However, during uphill condition the current required was quite high compared to current supplied to DC motor used on the same vehicle under the same condition. Therefore, to be comparable to DC motor, more research work is required on control strategies in order to improve the performance of induction motor used in EV.

Due to its low cost, robustness, high reliability and free from maintenance, automobile industry will certainly select cage induction motor as the most appropriate candidate for EVs [3]. Hence, we believe that the work carried out will contribute in development of future electric vehicles based on cage induction motor.

10 References

- [1] NehrdadEhSANI, YiminGao, Sebastien E. Gay, Ali Emadi, Modern Electric, Hybrid Electric, and Fuel Cell Vehicles- Fundamentals, Theory, and Design. CRC press, 2005.
- [2] SaidiHamza, Study and Realization of Solar Vehicle, Europe University Edition, Germany, ISBN : 978-613-1-55909-9 9 (in french), 2014
- [3] Hong CHENG, Xun GONG, Yun-Feng HU, Qi-Fang LIU, Bing-Zhao GAO, Hong-Yan GUO. Automotive Control: The State of the Art and Perspective. ActaAutomaticaSinica, Vol. 39, No.4, p 322-346, 2013
- [4] Muhammed H. Rachid, Power Electronics Circuit, Devices and Applications, 3rd Edition, 2004.
- [5] Llor.M.A. – Commande directe de couple à fréquence de modulation constante des machines synchrones à aimants permanents. Thèse de doctorat, université INSA, Lyon, France. 2003.

[6] Gaber El-Saady, El-Nobi A. Ibrahim, Mohamed Elbesealy. V/F Control of Three Phase Induction Motor Drive with Different PWM Techniques. Innovative System Design and Engineering. IISTE Vol4, No. 14, p 131-144, 2013

[7] Marwam A. A. Badran, Ahmad M. Tahir and Waleed F. Faris - Digital Implementation of Space Vector Pulse Width Modulation Technique Using 8-bit Microcontroller. World Applied Sciences Journal 21, page 21-28, 2013

[8] <http://www.alldatasheet.com/datasheet-pdf/pdf/82578/TI/TMS320F2812.html>

[9] Yashasvi V M & Basawaraj Amarapur, Digital Signal Processing Based Speed Control of Induction Motor Drive System International Journal on Advanced Electrical and Electronics Engineering, (IJAE), ISSN (Print): 2278-8948, Volume-1, Issue-1, 2012

[10] Sujeet Kumar Soni, Anil Gupta. Analysis of SVPWM Based Speed Control of Induction Motor Drive with using V/F Control Based 3 Level Inverter, IJSET Vol. No.2, Issue No. 9, 2013.

[11] Alternative Energy Technical Regulations. FIA Sport / Technical Department, 2006.

[12] <http://www.irf.com/product-info/datasheets/data/iramy20up60b.pdf>